



COMSOF

Edmund | Shao Qi

Introduction

- ▶ Spin-off company in 1998
- ▶ Fiber network consultancy company
- ▶ Two products:
 - FiberPlanIT
 - INCA

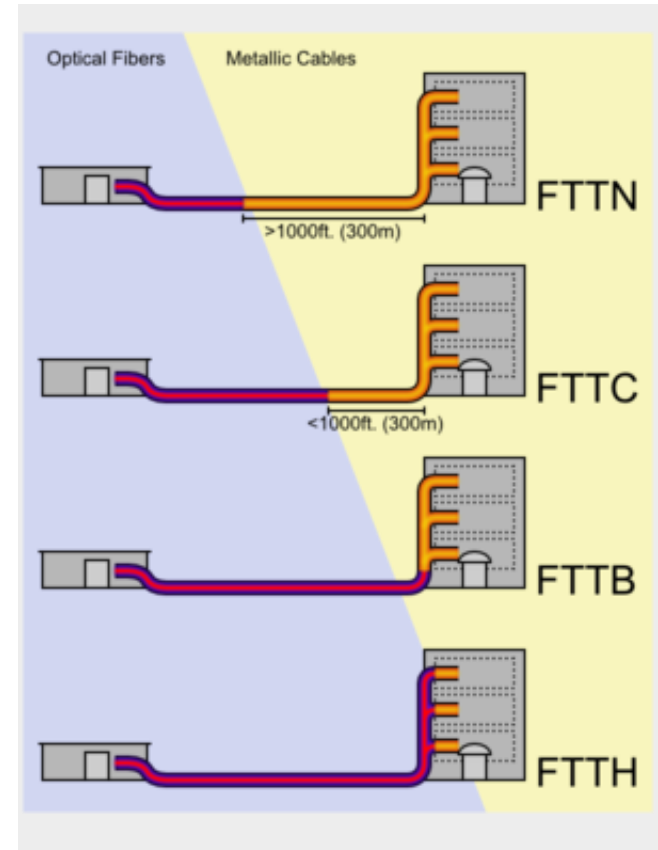

European Region FTTH Forecast

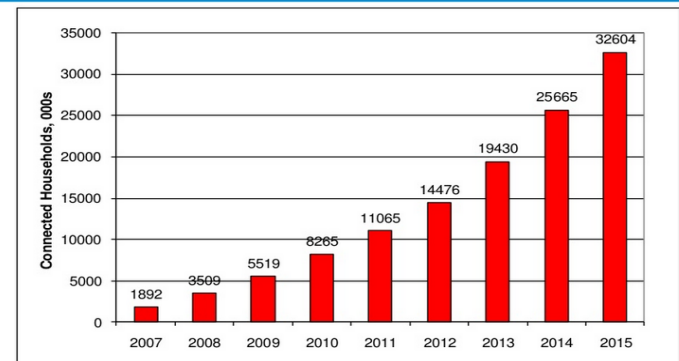

SWOT ANALYSIS

Strength	Weakness
Professional & Experienced	Thin resources in human capital
Dedicated Products	Lack of global presence
Good reputation	Little exposure of demo video and testimonials
Scalable business model	Insufficient marketing strategy
Flexible revenue model	

SWOT ANALYSIS

QaDIM

Complementary functions	Add a feature	Embed
Combine two products	Existing Product	Separate into two products
Substitute components, materials	Remove a feature	Reduce components / size

Opportunity	Threat
Extend consultancy service areas	Indirect competition from other companies
Expand markets	
Complementary functions	

Asia Expansion : Singapore

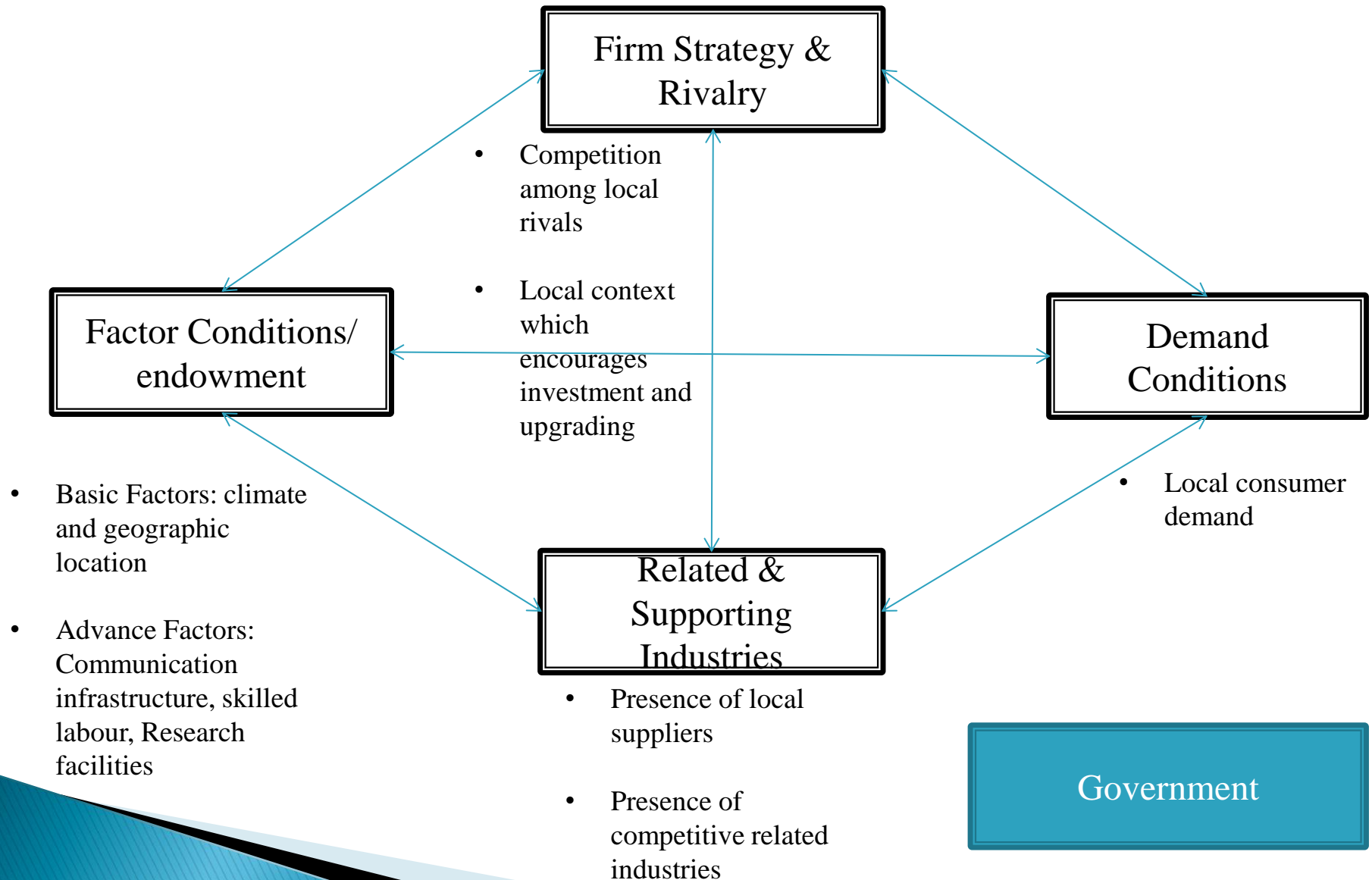

Household Download Index

Based on millions of recent test results from Speedtest.net, this index compares and ranks consumer download speeds around the globe. The value is the rolling mean throughput in Mbps over the past 30 days where the mean distance between the client and the server is less than 300 miles.

15.25

Mbps

ALL COUNTRIES

Graph Period:
Apr 6, 2011 - Oct 5, 2013

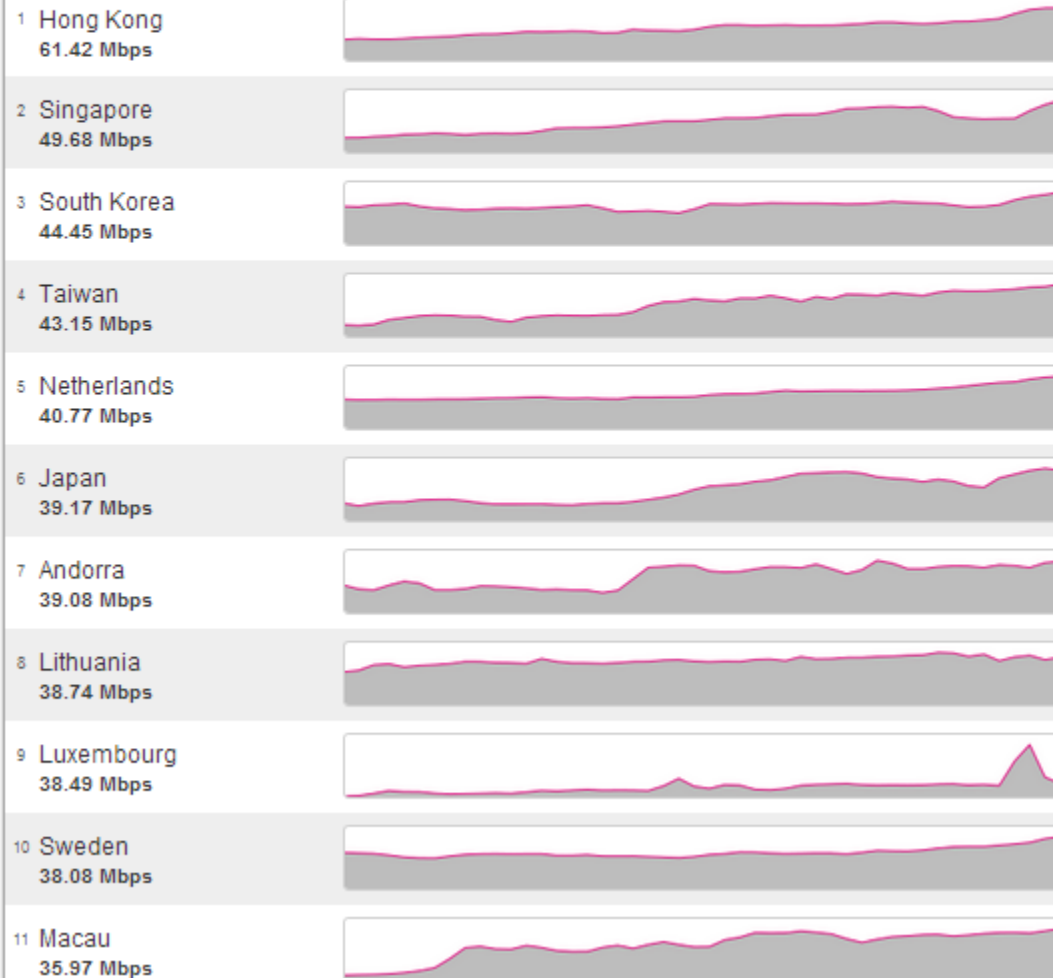

Government Support

Speech by Minister for communication and information on 18 June 2013

- Sets the direction for Singapore's infocomm and media
- New Infocomm Media Masterplan for year 2025

Fiber Optic Scene

Operating companies

Network company

BlueTel



nucleus
connect



Tata Communications

VIEWQWEST



Optical Fiber Subscription

	JUL	AUG	SEP	OCT	NOV	DEC
Total Optical Fibre Broadband Subscription (i.e., offered via PON or Active Ethernet) ¹²	198,400	212,800	231,200	247,600	266,500	284,700

- OpenNet announces that the number of fiber broadband subscribers reached about 380,000 as of end June 2013
- 192,000 of them are Singtel subscribers

<http://www.opennet.com.sg/press/record-high-demand-for-fibre-in-june-2013/>
<http://info.singtel.com/annualreport/2013/operating-and-financial-review/singapore-business.html>

Future Possibilities

- ▶ Long term partnership with telecommunication company like Singtel (associates with 25 countries)
 - ▶ Collaboration with University projects to have wider exposure on the technology and application
- 

MAJOR ISPS

ALL ISPS

1	Viewqwest Pte Ltd ⓘ 171.09 Mbps ★★★★★ 4.5	
2	M1 Ltd ⓘ 108.51 Mbps ★★☆☆☆ 2.1	
3	MobileOne ⓘ 66.18 Mbps ★★☆☆☆ 2.4	
4	MyRepublic ⓘ 64.05 Mbps ★★★★★ 3.8	
5	MobileOne Ltd. Mobile/Internet S... ⓘ 62.08 Mbps ★★☆☆☆ 2.2	
6	StarHub Internet Pte Ltd ⓘ 54.95 Mbps ★★☆☆☆ 2	
7	SingNet ⓘ 52.41 Mbps ★★☆☆☆ 2.3	
8	M1 Connect Pte Ltd ⓘ 35.01 Mbps ★★☆☆☆ 3.2	
9	TEMASE ⓘ 29.64 Mbps ★★☆☆☆ 2.9	
10	StarHub Cable Vision ⓘ 24.44 Mbps ★★☆☆☆ 2.3	
11	M1 CONNECT PTE. LTD. ⓘ 19.31 Mbps ★★☆☆☆ 2.9	
12	LGA International ⓘ 17.81 Mbps ★★☆☆☆ 2.5	
13	NTT SINGAPORE PTE LTD ⓘ 17.22 Mbps ★★☆☆☆ 3.4	

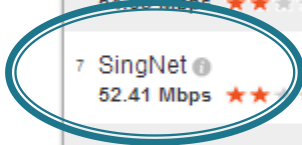

Thank you!

